

M577 U.S. ARMoured COMMAND POST CAR



1/35 MILITARY MINIATURE SERIES



M577

Since World War II proved that close cooperation between tank troops and mechanized infantry was essential to victory, it has become more and more important. Armoured personnel carriers which follow main battle tanks and take part in mobile warfare have become indispensable also to modern warfare. Because mobile warfare naturally enlarges the area of operations, it has become necessary for division-, brigade- and battalion-level commanders and staff officers to use command tanks or command post vehicles equipped with command and communication mechanism by means of which they can manoeuvre their units.

On the basis of experience in World War II and atomic test results, the U.S. Army has developed armoured personnel carriers under new ideas to ensure the new tactical employment of tank troops and mechanized infantry. The U.S. Army's ideas on command tanks or command post vehicles have been profoundly influenced by the armoured personnel carriers. To understand the M577/M577A1 light armoured command post vehicles now in active service, it is necessary to look back upon the development of the armoured personnel carriers.

Armoured personnel carriers used at the end of World War II by the U.S. Army armoured divisions' tank troops and mechanized infantry units consisted of the half-track M3 series, M20 general purpose wheeled car and M39 general purpose full track car. These open-top vehicles, however, were considered to be unsatisfactory as the main equipment of mechanized infantry units under new ideas and unsuitable for following tank troops or for the duties of infantry fighting vehicles whose crew were to fight both inside and outside them.

M44 Armoured Personnel Carrier

In 1945, International Harvester Corp. made an

experimental armoured personnel carrier named "T41E1" as a successor to the three existing armoured personnel carriers. This vehicle had box-shaped body totally enclosed with armour and accommodated as many as 27 men. Being too heavy and difficult to control, it proved unsatisfactory from a tactical point of view. Although it was officially accepted as the M44, actual production was limited in number. The M44, however, was a prototype of U.S. armoured personnel carriers now in active service.

M75 Armoured Personnel Carrier

In 1948, International Harvester Corp. designed

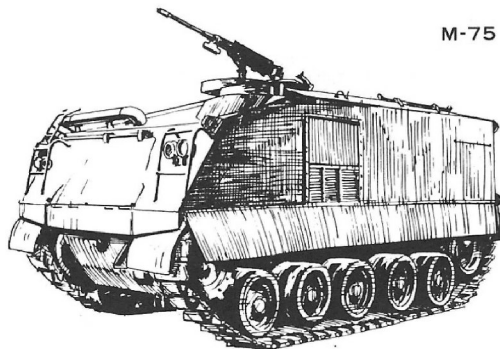

M-75

a smaller and typical armoured personnel carrier as a successor to the M44. This vehicle was originally named "T18" but, after various tests, renamed "T18E2". In 1952, it was officially designated "M75" and put to production by International Harvester Corp. and Ford Machinery Corporation (FMC). In 1953, vehicles of this type began to be delivered to mechanized infantry battalions in armoured divisions. The M75 armoured personnel carrier was developed as part of the light vehicles in the Unified Armoured Fighting Vehicle Development Program. Its box-shaped body was totally enclosed with

armour. The crew were 12. A 12.7 mm machine gun was carried on the upper hull. In the Korean War, the M75 armoured personnel carrier saw action with the M39 general purpose full track car and proved itself to be able to give sufficient mobility to regular infantry.

M59 Armoured Personnel Carrier

The M59 had box-shaped body totally enclosed with armour and could travel on the water.

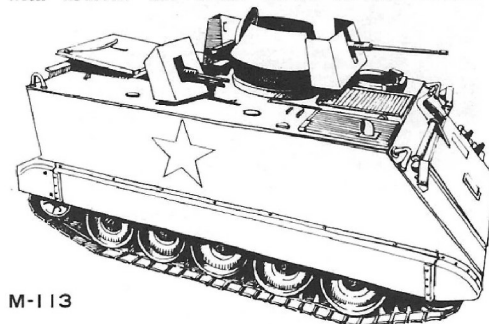

M-113

The crew were 12. From 1952 to 1953, the vehicle, then provisionally named "T59", was jointly developed by FMC and Ordnance Department of Machinery & Chemical. In February 1955, it was officially accepted by the Army. In those days, 85 vehicles of this type were used by each mechanized infantry battalion.

M113 Armoured Personnel Carrier

The development of the M113 was started by FMC in 1957 and the production was initiated in mid 1960. Its features include low production costs, aluminum alloy armour and amphibious ability. It is said to be the best armoured personnel carrier ever used by the U.S. Army. Vehicles of this type are being used also by the ground troops of West Germany, Switzerland, Canada, Italy, the Netherlands, Denmark, Spain, Greece, Turkey, Iran, Pakistan, Thailand, South Korea, Norway and Jordan. While the M113 is

powered by a gasoline engine, another version named "M113A1" is equipped with a diesel engine. A large number of variations based on them are being manufactured.

The M577 and M577A1 light armoured command post vehicles were developed on the basis of the M113 series and put to production by FMC in 1962. They are used by the headquarters of armoured and mechanized divisions, by brigade and battalion staff officers in charge of operations or logistics, and as command posts. They have cross-country mobility, amphibious ability and air transportability. They carry 5 men including the driver and 3-5 radio sets according to the duties of the staff officer. In the front part of the hull, there are a generator (28V, 105A) to supply electric power to dome-shaped lights for the crew, blackout lights, radio sets and accessories. The rear of the hull has an extension which makes it possible to take the command of and communicate with units in all sorts of weather or even under air defence warning conditions.

Body: The M577 series has box-shaped body protected with light alloy armour. The body has power plant compartment in the frontal right, driving compartment in the frontal left and crew compartment in the rear. Since it has a higher ceiling than the M113, the crew can operate the radio sets in a standing posture.

Engine: The M577 series is powered by either a gasoline or diesel engine. The M577 has a Chrysler 75M 4-cycle V 8-cylinder OHV water-cooled gasoline engine offering 215 hp, while the M577A1 carries a 5063-5290 2-cycle V 6-cylinder water-cooled diesel engine of 210 hp made by Detroit Diesel Engine Manufacturing Department of General Motors Corp.

Transmission: The M577 has GMC Allison TX 200-2 B automatic fluid transmission with 6 forward and 1 reverse speeds. The M577A1 uses Allison TX 100-1 automatic fluid transmission with 4 forward and 1 reverse speeds. The M577 is equipped with double-acting control differential and designed to make only slow turns. The M577A1 has a disc clutch on the input train of each final drive gear and can make both slow and quick turns.

Tracks and suspension: The M577 series has single-pin steel tracks with rubber pads and uses torsion bar suspension.

Main equipment: The M577 series only carries



equipment required for its purposes and does not have offensive or defensive weapons. Needless to say, the main equipment consists of AM and FM radio sets. The AM sets are the AN/GRC 19, AN/VRC 24, AN/CRR 5 and AN/VRC 29. The FM sets include the AN/VRC 3 — 8 & 10 (for communications with troops in rear), AN/VRC 13 — 15 & 20 — 22 (for communications with combat troops during advance), and AN/DIC 1 interphone. New FM sets as follows are also used: the AN/VRC 46, 47 & 29 and AN/VIC 1 (V).

The GRC series can be used in communications with fixed radio relay stations, tactical radio sets in outpost areas and aircraft radio sets. The M577 series carries different radio sets according to the duties of the staff officer on the vehicle.

The M577 and M577A1 are naturally used by the cores of the unit. In the armoured and mechanized divisions, the headquarters intelligence and operation units use one vehicle each, the engineer battalion headquarters' operation unit uses two, the brigade headquarters' commander and staff squad use four (for command, personnel & commissariat, intelligence and op-

eration units) and the signal squad uses one. The divisional tank, mechanized infantry and mechanized cavalry battalions have five or six vehicles each. The divisional medical corps uses one to command vehicles which send the wounded to the rear.

In World War II, the U.S. Army, unlike the German Army, had no typical command tanks and used instead armoured fighting vehicles including tanks with their interior modified accordingly. The situation remained unchanged for some years after the war. It was not until the M577 and M577A1 appeared early in the 1960's that the U.S. Army had typical command tanks.





READ BEFORE ASSEMBLY.
ERST LESEN — DANN BAUEN.

★Study the instructions and photographs before commencing assembly.
 ★You will need a sharp knife, a screwdriver, a file, and a pair of pliers.
 ★Do not break parts away from sprue, but cut off carefully with a pair of pliers.
 ★Use glue sparingly. Use only enough to make a good bond. Apply cement to both parts to be joined.
 ● This mark shows the colour this part should be painted.

★Vor Beginn die Bauanleitung studieren und den Nummern nach die Elemente zusammenbauen.
 ★Bauteile nicht vom Spritzling abbrechen, vorsichtig abschneiden oder abwickeln, Teile vor Kleben zusammenhalten, auf genauen Sitz achten. Nicht zuviel Klebstoff verwenden. Kleine Teile hält man mit Pinzette fest.
 ★Abziehbilder vorsichtig von der Unterlage im Wasser abschieben, auf richtigen Sitz achten und gut trocknen lassen.

1 Construction of Wheels
Zusammenbau der Räder

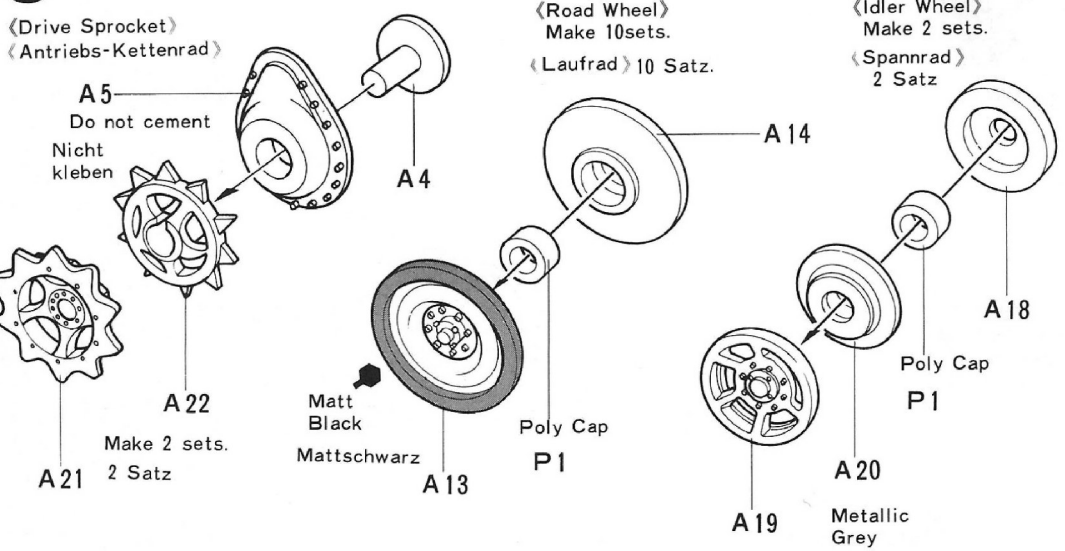

2 Fixing of Wheels
Einbau der Räder

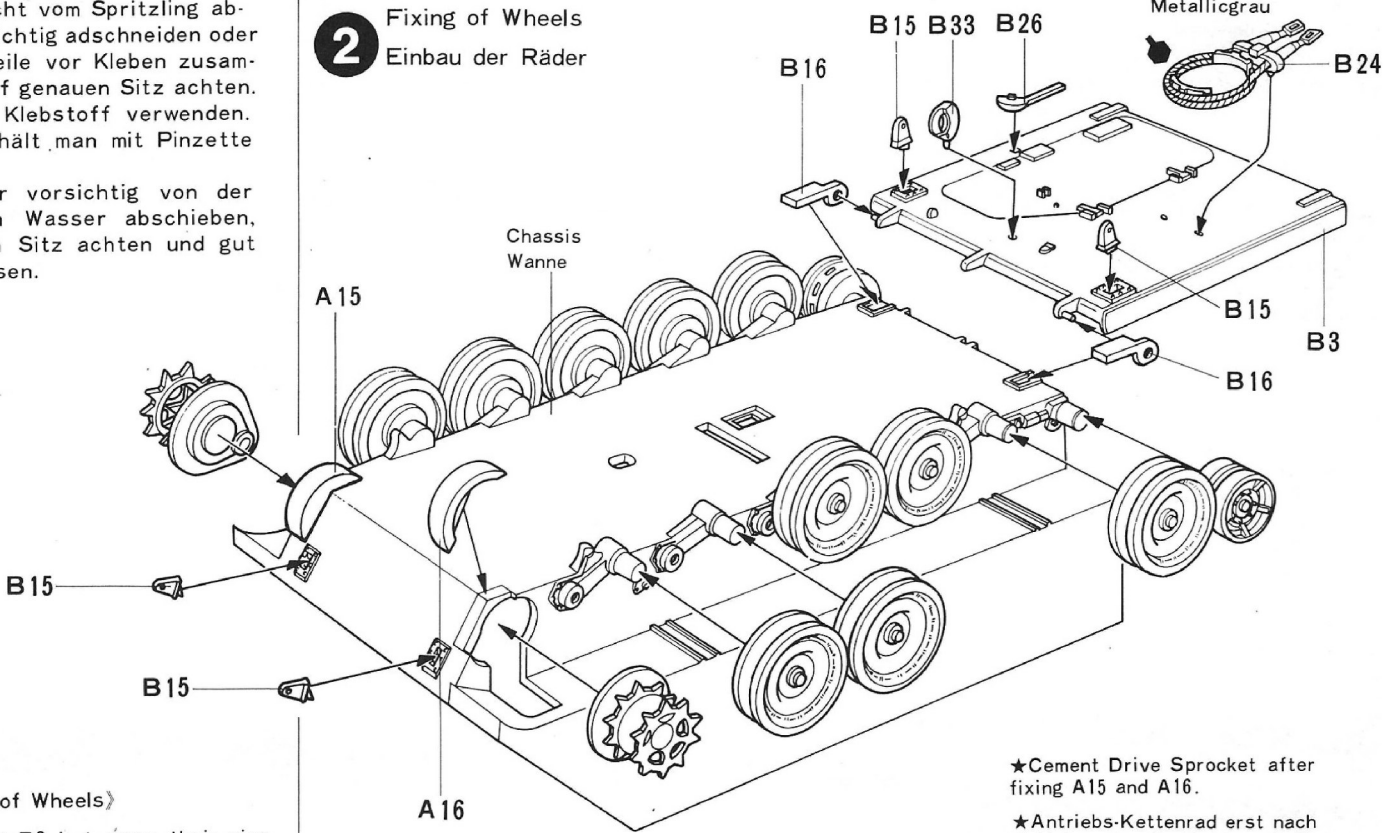

★Cement Drive Sprocket after fixing A15 and A16.
 ★Antriebs-Kettenrad erst nach einkleben der Verkleidung A 15 und A 16 festkleben

2 (Fixing of Wheels)

Do not cement B3 but pass their pins through B16 and cement B16 to Chassis.

(Einbau der Räder-Heckklappe)

Die Räder werden nur aufgesteckt. Die Scharniere B 16 in die Zapfen an der Heckklappe stecken und nur die Scharniere B 16 auf die Wanne kleben. Sonst sämtliche Teile wie im Bild gezeigt ankleben.

3 Fixing of Rear Parts
Heckplatte

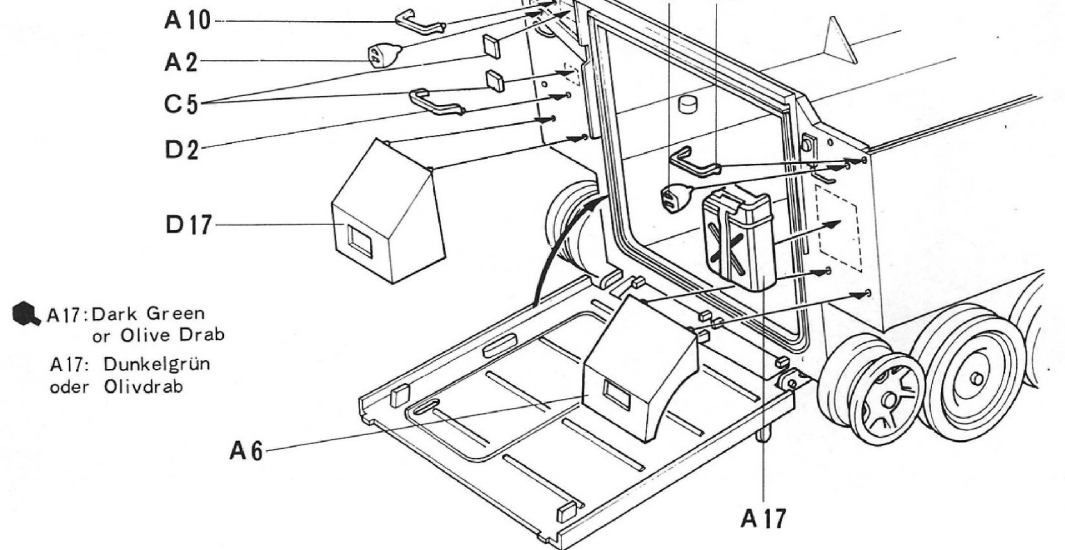

● A17: Dark Green or Olive Drab
 A17: Dunkelgrün oder Olivdrab

Tamiya photo albums
 Tamiya has a complete selection of photo albums on diorama building, prize winning water line models; tanks; battlefields; remodeled 1/35 scale figures etc. Check with your nearest hobby supply house, or order direct from our factory.

4 (Fixing of Front Panel)

Cement B13 in an open position, and fix Driver's Figure inside this Hatch.

《Frontverkleidung》
siehe Bild.

Fahrer-Lücke geöffnet einbauen und Fahrer einsetzen.

《Construction of Tracks》
《Kettenmontage》

Melt pin heads with a heated screwdriver etc.

Zapfenkopf mit heißen Schraubenzieher verschmelzen.

Press Zusammenpressen

★Flatten this way.
★Abflachen

★Repair or strengthen the joint with using thread or stapler as shown right.

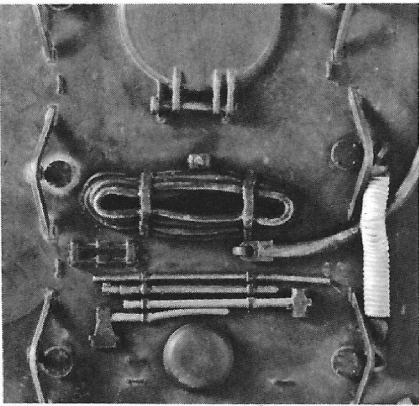

《Construction of Figure》



★D8 is Figure's Base. Fix at ④. Make Head Phone of plastic card and runner and fix.

Mikrofon aus Plasticband und Kabel anfertigen.

《2 times plan》
《2:1》

《Actual size》
《1:1》

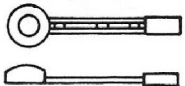

4 Fixing of Front Panel Frontverkleidung

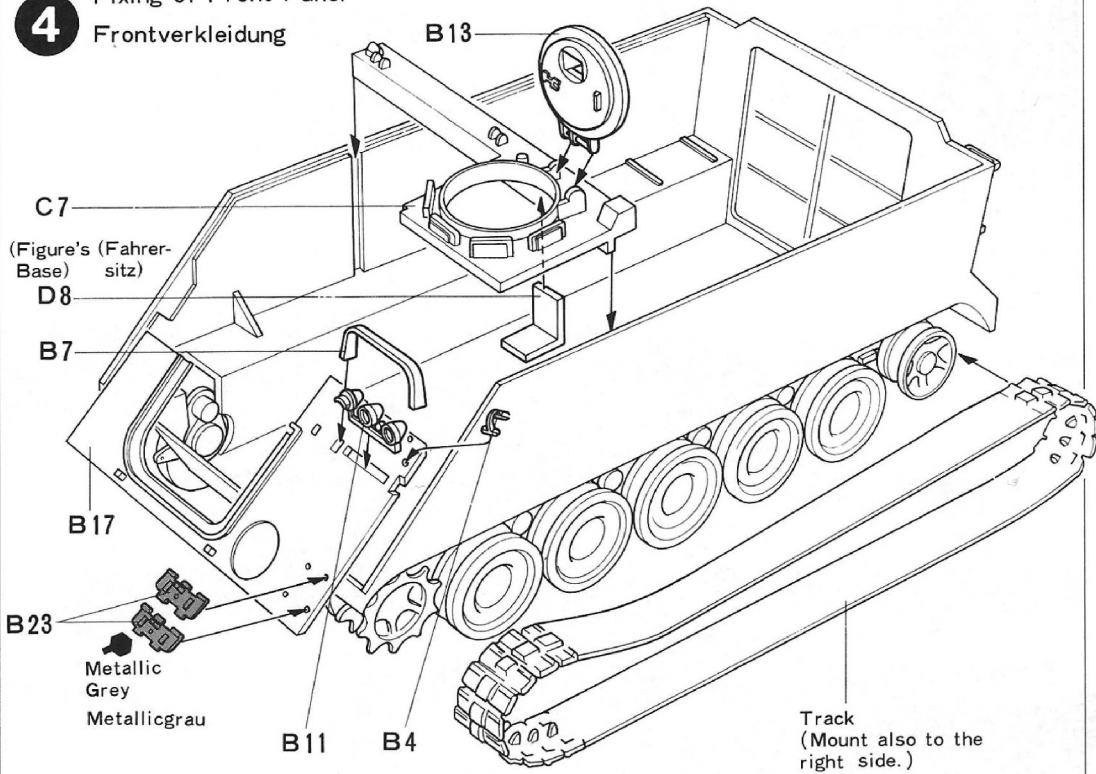

5 Construction of Upper Personnel Compartment 1 Deckplatte

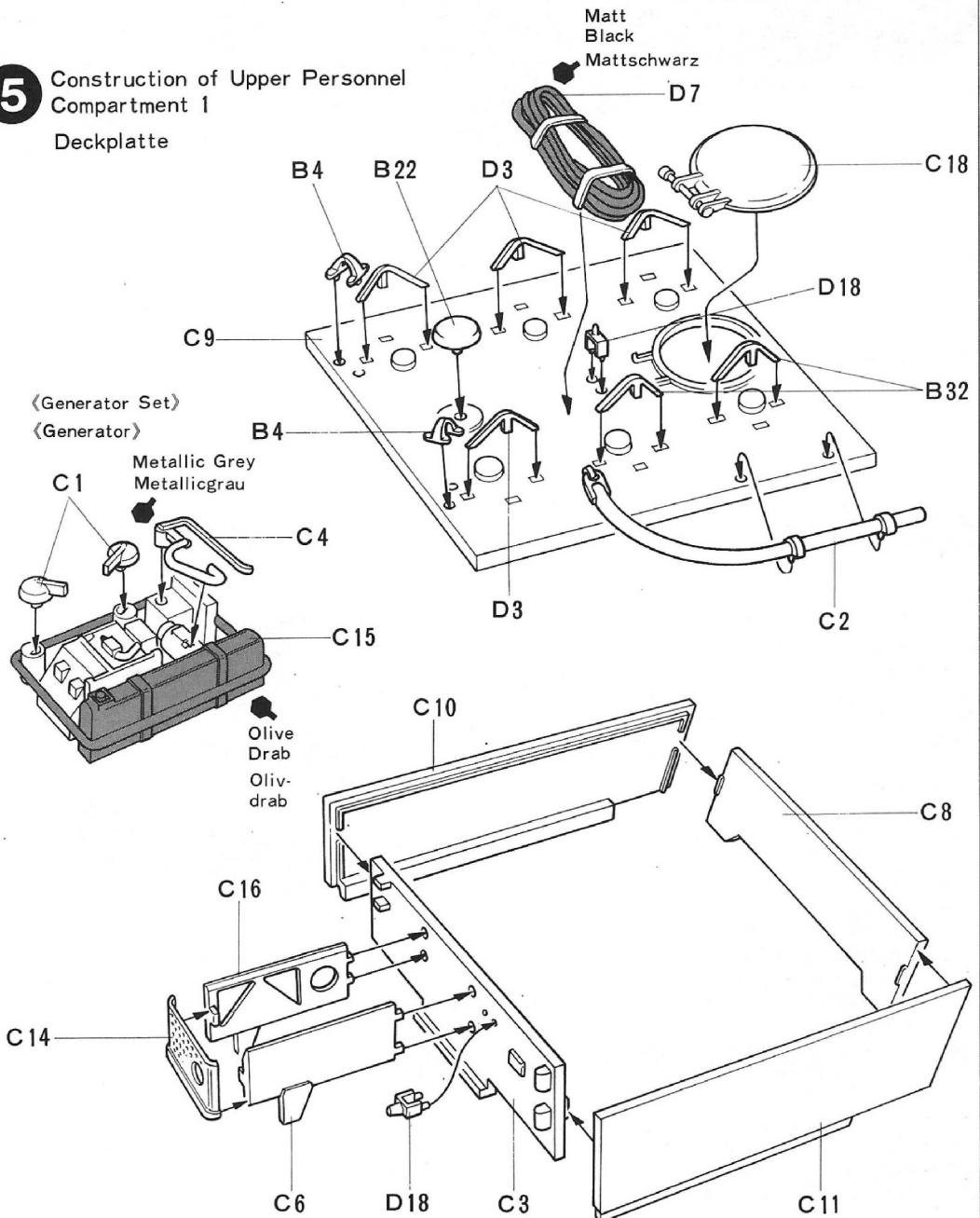

6 Construction of Upper Personnel Compartment 2
 Fix Extension Frameworks as shown below at the right side center after cementing D19 and D20.

Deck-Aufbau
 Rahmenteile erst ankleben nach Einbau der Halterungen D 20 und D 19.

7 Completion of M577
 Select either one of two positions of Trim Vane B2, when crossing water (lowered) or when running on land (lifted up).

Endmontage
 Es gibt zwei Möglichkeiten die Trimmplatte B 2 einzubauen, heruntergelassen im Wasser unter Verwendung von Teil B 27 oder hochgezogen an Land unter Verwendung von Teil B 28.

Construction of Power Plant Door
 Motorabdeckung

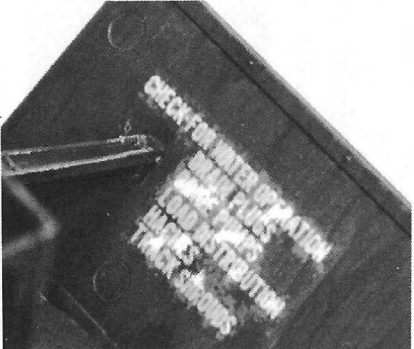
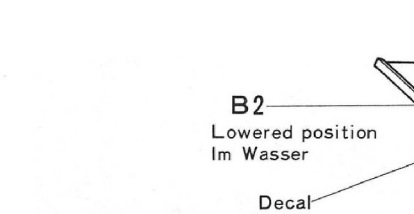
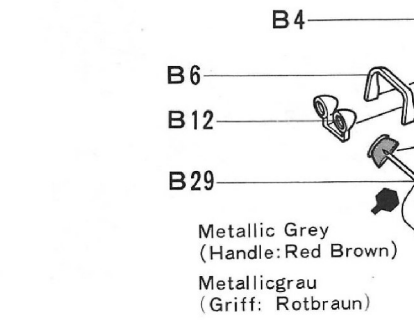
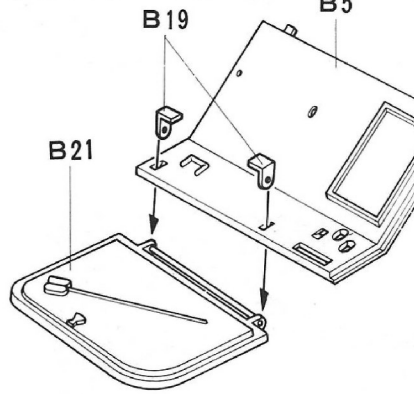

6 Construction of Upper Personnel Compartment 2
 Deckaufbau

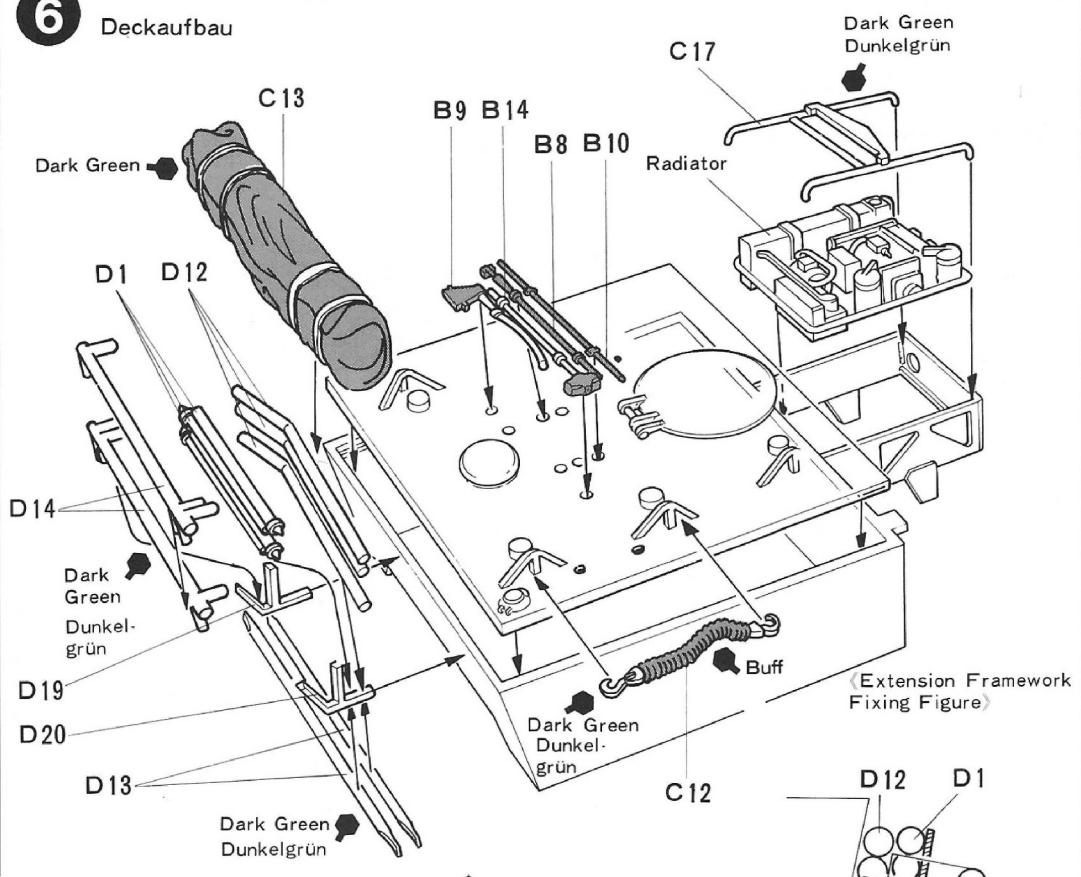

B9, B14: Metallic Grey (Handle: Red Brown)
 B10: Metallic Grey
 B8: Red Brown (Rotbraun)

7 Completion of M577
 Endmontage

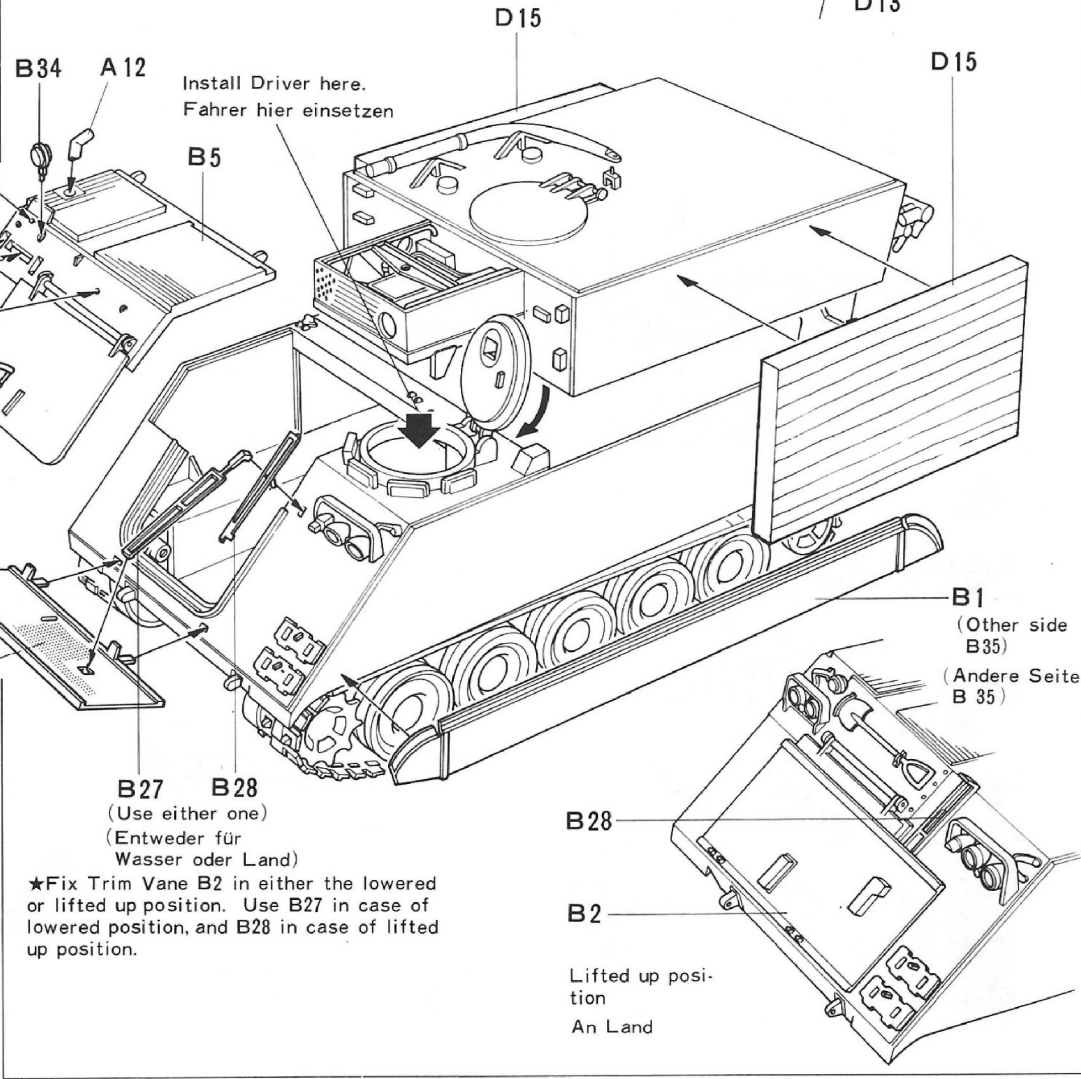

Install Driver here.
 Fahrer hier einsetzen

★Fix Trim Vane B2 in either the lowered or lifted up position. Use B27 in case of lowered position, and B28 in case of lifted up position.

《Standard U.S. Infantry Equipment》
 《U.S. Infanterie-Ausrüstung》



Shovel (Spaten) Dark Green + Khaki

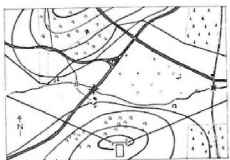
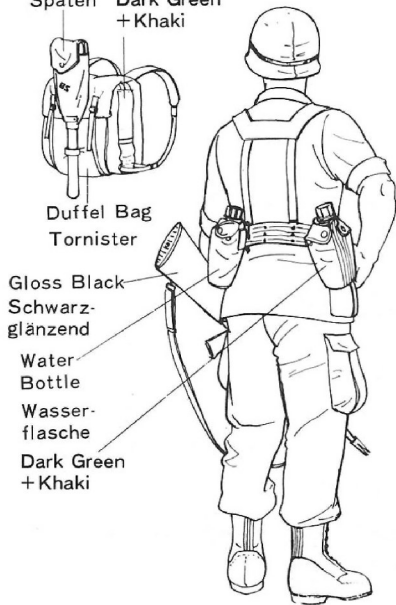

★Cut out the above map and use in diorama.

★Ausschneiden der oben Karte und benutzen in Diorama.

8 Construction of Accessories

《Desk》
 《Tisch》

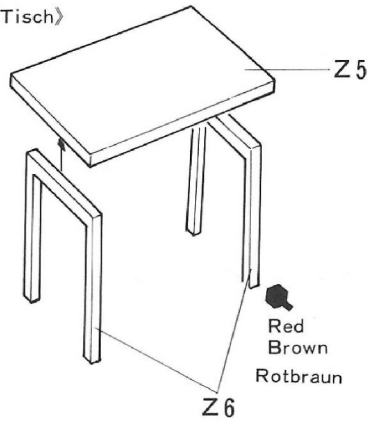

《Chair》
 《Stuhl》

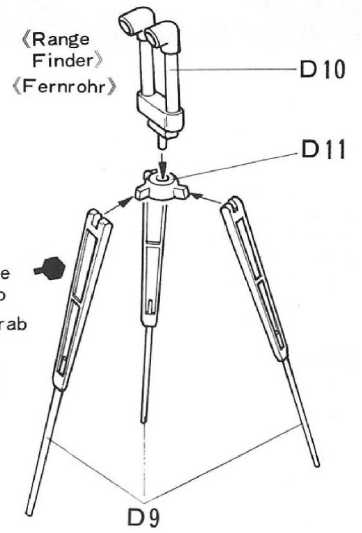

9 Construction of Figures

《Figure D》

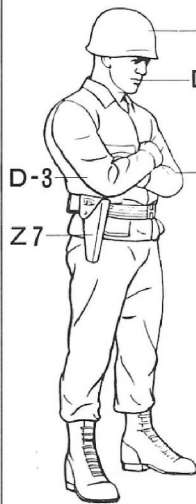

《Figure A》



《Figure C》



《Figure B》

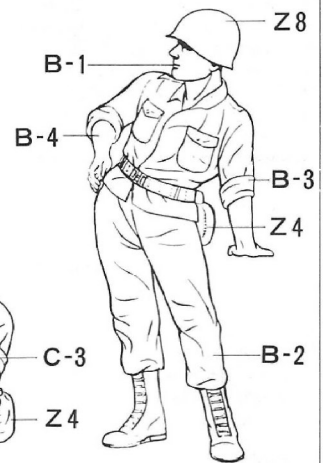

10 Location of Figures and Accessories

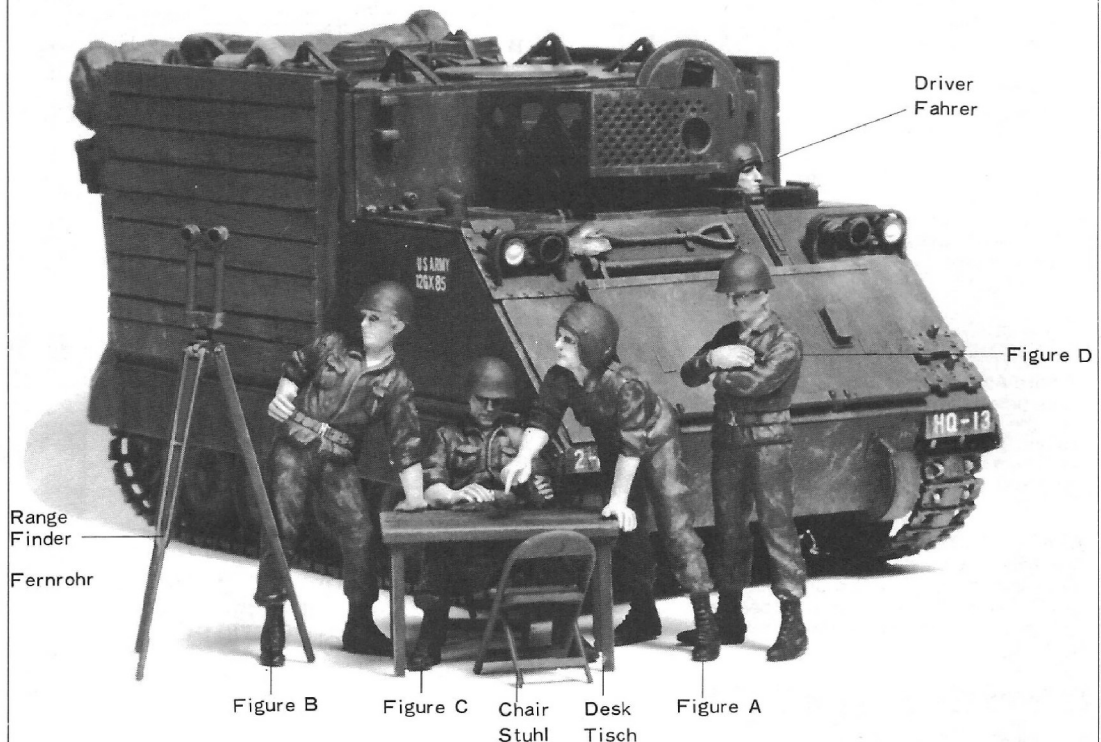

PARTS

A PARTS

- 1. Unnecessary
- 2. Taillights
- 3. Unnecessary
- 4. Drive Shafts
- 5. Final Drives
- 6. Fender B
- 7. Unnecessary
- 8. Unnecessary
- 9. Unnecessary
- 10. Rear Handrails
- 11. Unnecessary
- 12. Muffler
- 13. Road Wheels A
- 14. Road Wheels B
- 15. Final Case A
- 16. Final Case B
- 17. Water Tank
- 18. Idler Wheel B
- 19. Idler Wheel A
- 20. Idler Wheel C
- 21. Drive Sprocket A
- 22. Drive Sprocket B
- 23. Fuel cap

B PARTS

- 1. Skirt A
- 2. Trim Vane
- 3. Ramp
- 4. Suspender Hooks
- 5. Engine Compartment Cover A
- 6. Light Cover B
- 7. Light Cover A
- 8. Tool A
- 9. Axe
- 10. Tool B
- 11. Light A
- 12. Light B
- 13. Driver's Hatch
- 14. Hammer
- 15. Hooks
- 16. Hinges for Ramp
- 17. Front Panel
- 18. Unnecessary
- 19. Hinges for Power Plant Door
- 20. Unnecessary
- 21. Power Plant Door
- 22. Ventilator
- 23. Spare Track Shoe
- 24. Wire Rope
- 25. Unnecessary
- 26. Ramp Handle
- 27. Trim Vane Extension A
- 28. Trim Vane Extension B
- 29. Shovel
- 30. Unnecessary
- 31. Unnecessary
- 32. Handrail
- 33. Towing Pintle
- 34. Horn
- 35. Skirt B

C PARTS

- 1. Generator Set Part A
- 2. Davit
- 3. Upper Personnel Compartment (Front)
- 4. Generator Set Part B
- 5. Receptacle
- 6. Generator Set Enclosure (Left)
- 7. Front Deck
- 8. Upper Personnel Compartment (Rear)
- 9. Upper Personnel Compartment (Roof)
- 10. Upper Personnel Compartment (Right)
- 11. Upper Personnel Compartment (Left)
- 12. Pulley
- 13. Covered Extension
- 14. Generator Set Enclosure (Front)
- 15. Generator Set
- 16. Generator Set Enclosure (Right)
- 17. Generator Framework
- 18. Commander's Hatch

D PARTS

- 1. Extension Legs
- 2. Rear Hinges
- 3. Handrails
- 4. Driver's Left Hand
- 5. Driver's Right Hand
- 6. Driver's Upper Half
- 7. Cable
- 8. Base for Driver
- 9. Range Finder Leg
- 10. Range Finder
- 11. Range Finder Stay
- 12. Extension Framework A
- 13. Extension Framework B
- 14. Extension Framework C
- 15. Extension Floor Plates
- 16. Unnecessary
- 17. Fender A
- 18. Hatch Bumper
- 19. Framework Stowage Brackets A
- 20. Framework Stowage Brackets B
- 21. Unnecessary



Tamiya Acrylic Paints

Need precise colour matching? Try the new Tamiya acrylic paints. Engineered by modelers for modeler's use. The final cover for the finest models. Insist on Tamiya for perfect results.

TAMIYA COLOR CATALOGUE

The latest in cars, boats, tanks and ships. Motorized, radio controlled and museum quality models are all shown in full color in Tamiya's latest catalogue. At your nearest hobby supply house.



TAMIYA
TAMIYA, INC.
3-7 ONDWARA, SHIZUOKA-CITY, JAPAN.

A

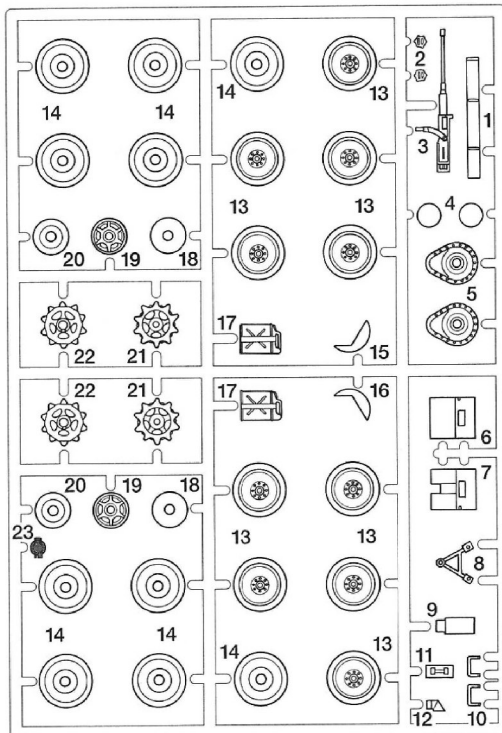

A23 is not used.

B

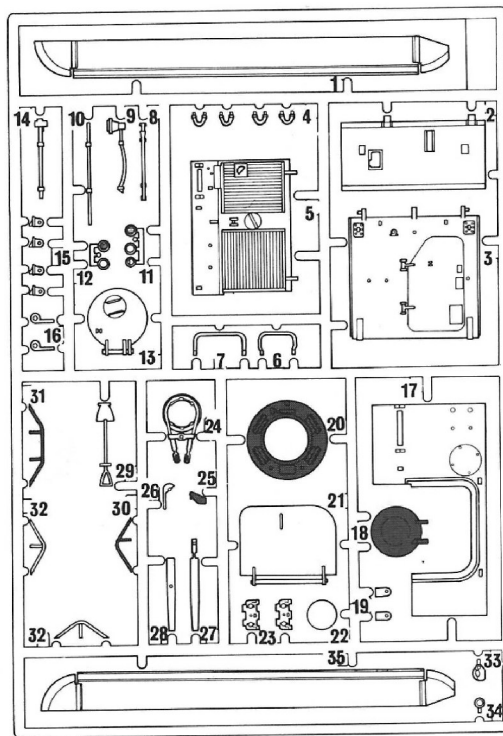

C

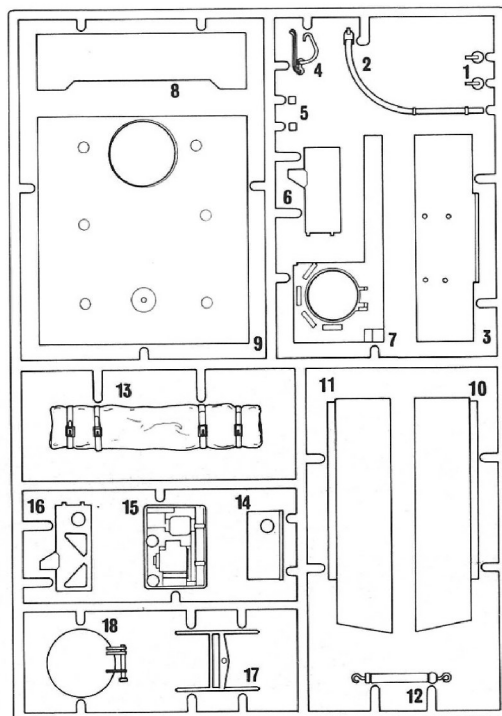

D

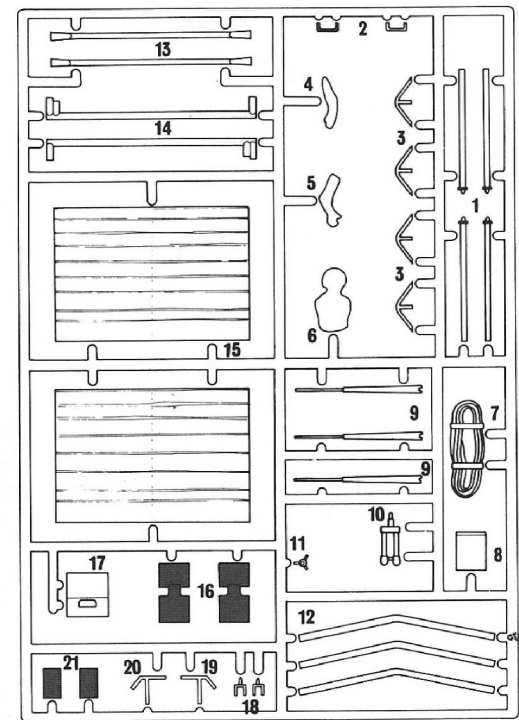

P

P2 are unnecessary.

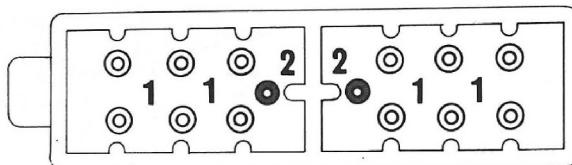

PAINTING



APPLYING DECALS

《Painting and Marking of M577》

The general painting colour of the M-577 is a single olive drab. For a camouflage effect, the following scheme is applied to the vehicle of the U.S. Troops stationing in West Germany.

- Sand
- Light Green
- Red Brown
- Black
- Metallic Grey (gun barrel etc.)

《Bemalung》

Die Standard Farbe des M 577 ist Olivdrab. Zur Tarnung verwenden die US-Truppen in Westdeutschland: Sand-hellgrün-rotbraun-schwarz. Gunmetall für Kanonenrohr etc.

2nd Armoured Division (Stationing in South Korea)

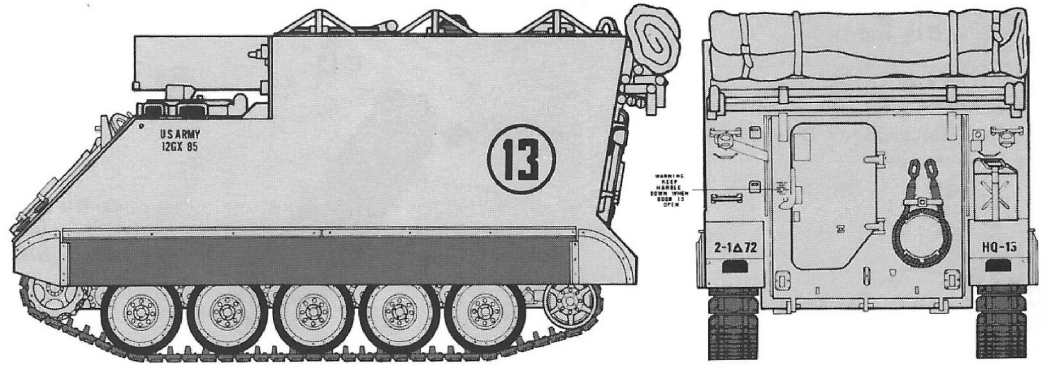

Olive Drab
Olivdrab

Metallic Grey
Metallicgrau

Buff

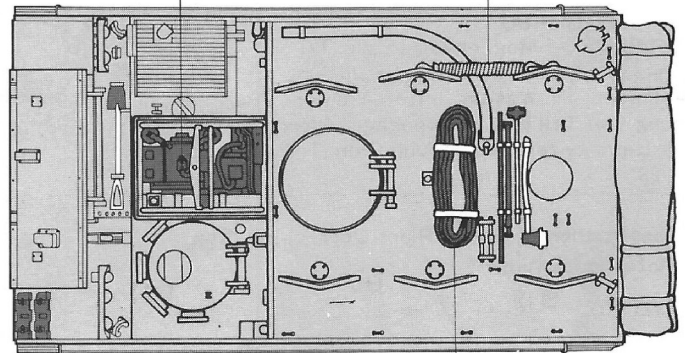
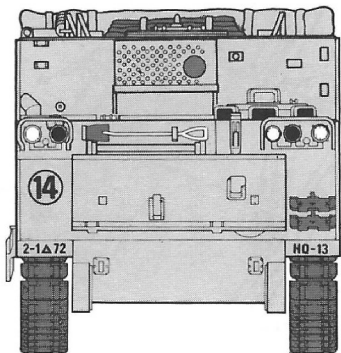

Matt Black
Mattschwarz

7th Armoured Division (Stationing in West Germany)

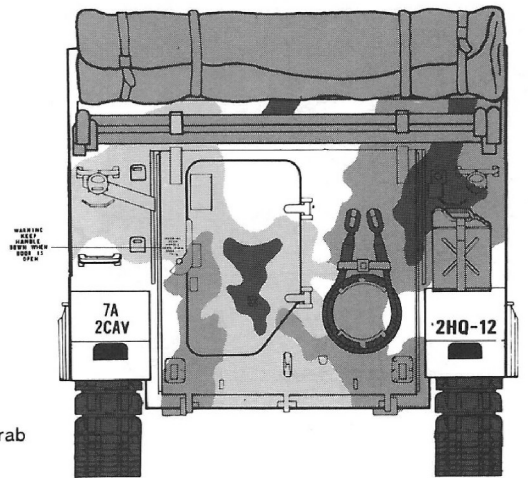
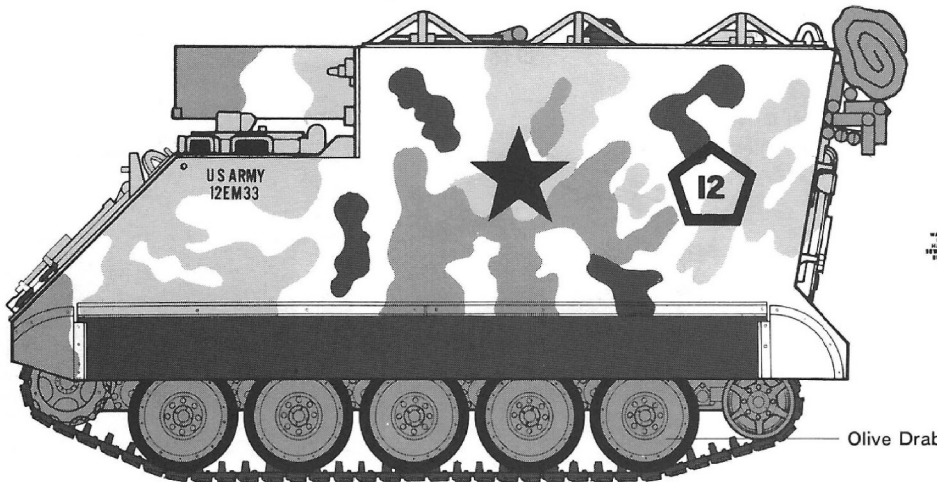

Matt Black
Mattschwarz



Dark Green: 3 + Dark Earth:
2 + Matt Yellow: 1
Dunkelgrün: 3 + dunkle Erde:
2 + mattgelb: 1



Red Brown: 2 + Buff: 3
Rotbraun: 2 + Buff: 3



Dark Yellow
+ Buff

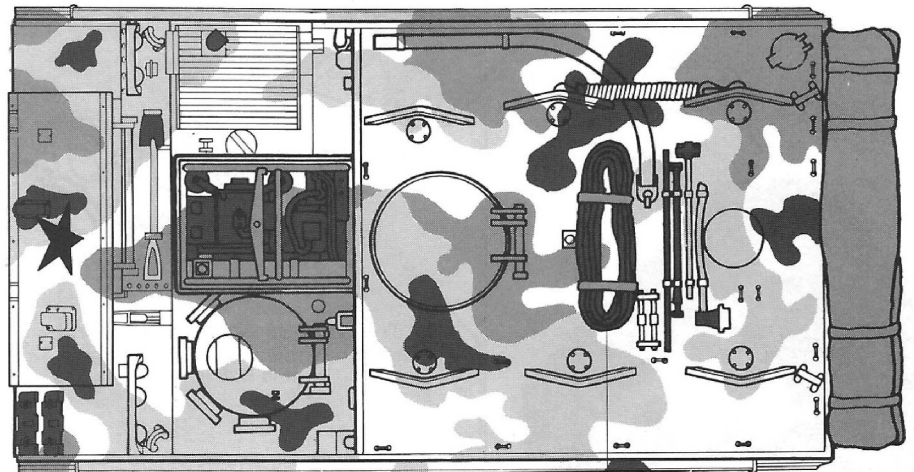
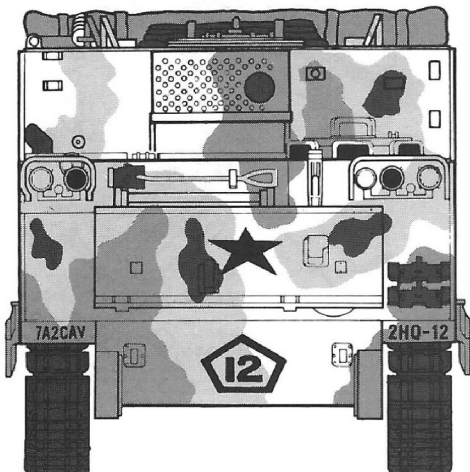

Matt Black
Mattschwarz